

Minuteman[®]
Parker[®]

Model: HT9605H
HT0165B

Hurricane Plus

OPERATION

SERVICE

PARTS

CARE

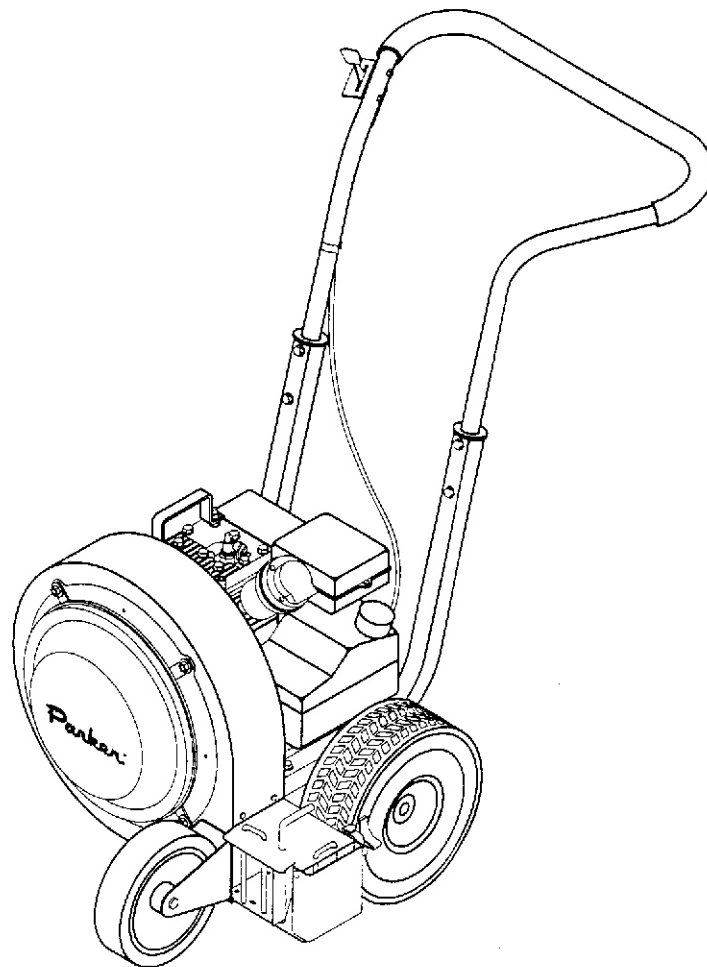

TABLE OF CONTENTS

General Safety Instructions	1 & 2
Warning Decal Placement	3
Assembly Instructions	4
Blower Assembly HT Series Mainframe	5
Engine Assembly	6 & 7
Warranty	Back Cover

SOUND		VIBRATION												
91 dB Operator	83 dB At 3m	12.0 m/s² At Operators Handles												
<p>Tests were conducted on 4-22-96 with calibrated sound and vibration equipment under the conditions noted below:</p> <table> <tr> <td>General Condition:</td> <td>Cloudy</td> <td>Wind:</td> <td>8 km/hr</td> </tr> <tr> <td>Temperature:</td> <td>15°C</td> <td>Humidity:</td> <td>85%</td> </tr> <tr> <td>Barometric Pressure:</td> <td>30.1</td> <td></td> <td></td> </tr> </table>			General Condition:	Cloudy	Wind:	8 km/hr	Temperature:	15°C	Humidity:	85%	Barometric Pressure:	30.1		
General Condition:	Cloudy	Wind:	8 km/hr											
Temperature:	15°C	Humidity:	85%											
Barometric Pressure:	30.1													

IMPORTANT SAFETY INSTRUCTIONS

READ ALL INSTRUCTIONS BEFORE USING

WARNING

- To prevent personal injury or property damage, do not attempt to start engine until all assembly steps are complete and you have read and understand the safety and operating instructions in this manual.
- Under California, and under laws of several other states, you are not permitted to operation internal combustion engines using hydrocarbon fuels on any forest covered, brush covered, or grass covered land, or on land with grain, hay, or other flammable agricultural crop, without an engine spark arrester in continuous effective working order. The engine on your power equipment, like most outdoor power equipment, is an internal combustion engine that burns gasoline, a hydrocarbon fuel. Therefore, your power equipment must be equipped with a spark arrester muffler in continuous effective working order. The spark arrester must be attached to the engine exhaust system in such a manner that flames or heat from the system will not ignite flammable material. Failure of the owner/operator of the equipment to comply with this regulation is a misdemeanor under California law, and may also be a violation of other state and/or federal regulations, laws, ordinances, or codes. Contact your local fire marshal or forest service for specific information about what regulations apply in your area.
- Walk, Never Run.
- Wear approved safety glasses when operating this equipment. The operation of any powered machine can result in foreign objects being thrown by high-speed rotating parts.
- Operate machine in daylight or good artificial light.
- Wear work gloves, sturdy footwear, and hearing protection when operating this equipment.
- Remove hearing protection and watch for traffic when operating near, or when crossing roadways.
- Before inspecting or servicing any part of equipment, shut off engine, disconnect spark plug wire from spark plug, and make sure that all moving parts have come to a complete stop. Be aware that rotating blades slow down gradually after engine is shut off.
- Exercise extreme caution on slopes and avoid excessively steep slopes.
- Never leave equipment unattended when engine is running. Shut off engine and disconnect spark plug wire from spark plug before leaving equipment.
- Do not blow any burning or smoldering materials such as cigars, cigarettes, ashes or cinders.
- Do not blow areas that have been recently treated with fertilizers, pesticides or herbicides. Follow chemical manufacturer's safety instructions regarding contact with treated areas.
- Thoroughly inspect the area where the machine is going to be used, and remove all objects that may be a hazard when thrown by the machine.
- Do not change the engine governor settings or overspeed the engine.
- Never allow children or untrained adults to operate this equipment.

- Keep the area of operation clear of all persons, particularly small children, and pets. Keep bystanders at least 25 feet away from the area of operation.
- Do not run engine in an enclosed area. Engine exhaust contains carbon monoxide gas, a deadly poison that is odorless, colorless, and tasteless. Do not operate this equipment near buildings, windows, or air conditioners.
- Do not allow hands or any other part of the body or clothing inside the vacuum inlet.
- Do not start engine or operate this equipment with any safety guards or housing removed.

DANGER

Gasoline is highly flammable and its vapors are explosive. To prevent personal injury or property damage:

- Do not add fuel if engine is running or still hot from recent operation. Allow engine to cool for at least three minutes.
- Do not fill fuel tank indoors. After filling, wipe up any spills and move away from gasoline fumes before starting engine.
- Do not allow open flame, matches, or smoking in area.
- Fill fuel tank with fresh, clean unleaded regular automotive gasoline (leaded regular and unleaded or leaded premium grades of gasoline are acceptable substitutes).
- Do not mix oil with gasoline.
- Clean the area around the fuel fill cap and remove the cap from the fuel tank. Insert a clean funnel into the fuel tank.
- Fill the tank to 1/2 inch below the bottom of the filter neck to provide space for any fuel expansion.
- Reinstall the fuel fill cap securely and wipe up any spilled gasoline.
- Store fuel in containers specifically designed for this purpose.

MAINTENANCE AND STORAGE

- a) Keep all nuts, bolts and screws tight to be sure the equipment is in safe working condition.
- b) Never store the equipment with fuel in the tank inside a building where fumes may reach an open flame or spark.
- c) Allow the engine to cool before storing in any enclosure.
- d) To reduce the fire hazard, keep the engine, silencer, battery compartment and fuel storage area free of grass, leaves or excessive grease.
- e) Check the catcher frequently for wear or deterioration.
- f) Replace worn or damaged parts for safety.
- g) If the fuel tank has to be drained, this should be done outdoors.

SAVE THESE INSTRUCTIONS

SAFETY DECALS

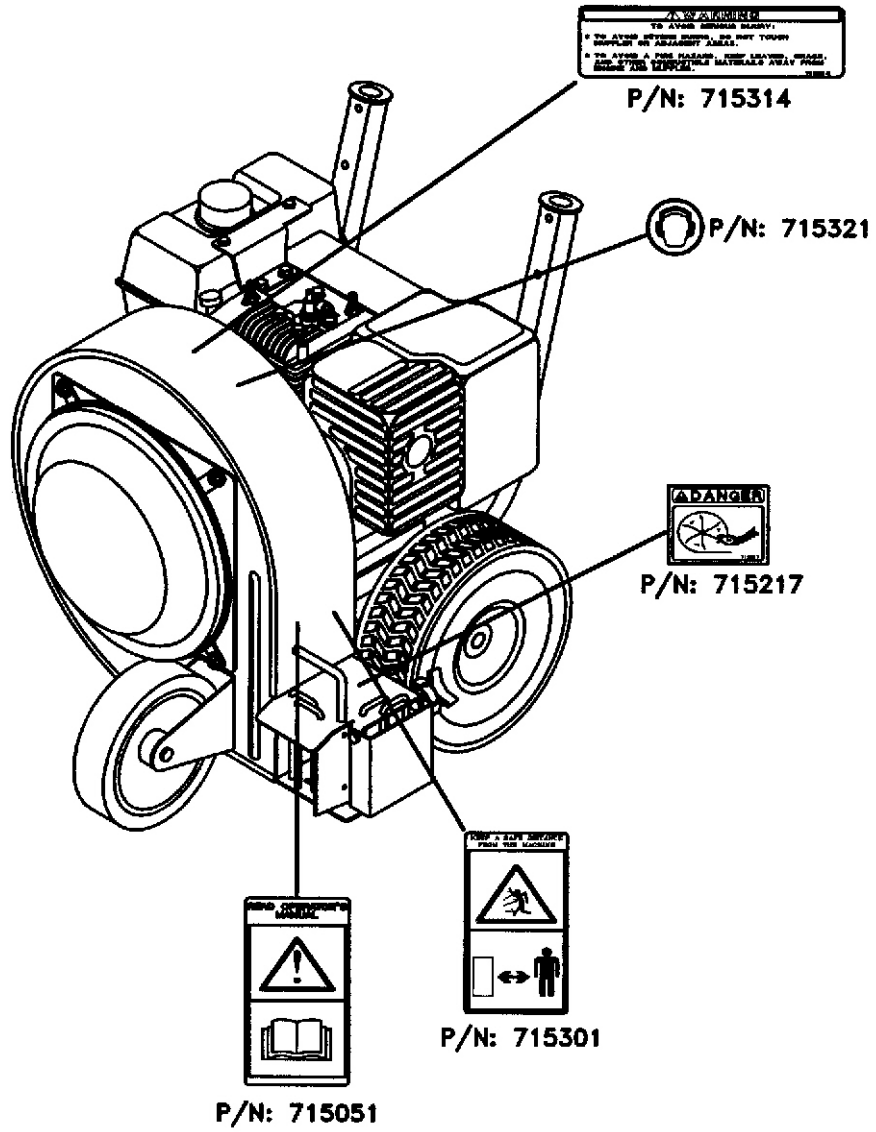

FRONT WHEEL ASSEMBLY

Install front wheel bracket (1) to front housing using 5/16 flat washer (2) and 5/16 nyloc nuts (3) and tighten. Install front wheel (4) into front wheel bracket (1). Slide nylon washer (7) onto clevis pin (5) and slide clevis pin (5) all the way through front wheel bracket (1) and front wheel (4). Slide second nylon washer (7) onto clevis pin (5) and secure with hairpin (6).

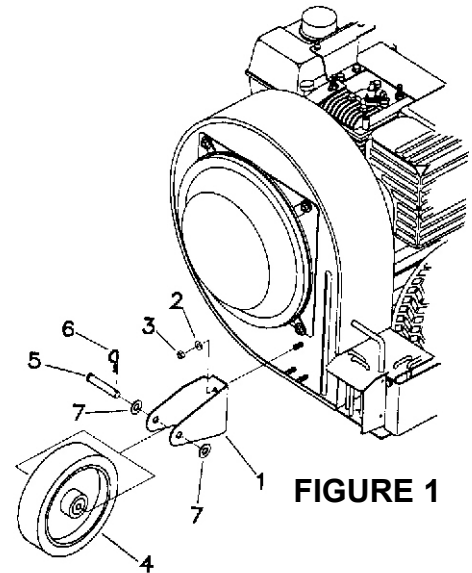

FIGURE 1

HANDLE ASSEMBLY

Install handle assembly to blower, place rubber shim (1) under handle strut (2) and place 5/16-18 x 2 bolt (4) and 3/8 washer (3) into holes in handle strut (2) and through frame (5) and tighten (not all the way) with 5/16 washer (6) and 5/16-18 nyloc nut (7). Place handle (8) into handle struts (2) and align holes in handle (8) and struts (2). Place 5/16-18 x 2 bolt (4) and 3/8 washer (3) into strut (2) and handle (8), as shown, and tighten with 3/8 washer (3) and 5/16-18 nyloc nut (7). Tighten bolts on strut/frame at this time. Pull pull-rope handle (9) towards strut (2) and install rope guide (10) around pull-rope. Place 1/4-20 x 2.5 bolt (11) through rope guide (10) and strut (2) and tighten with 5/16 washer (6) and 1/4-20 nut (12).

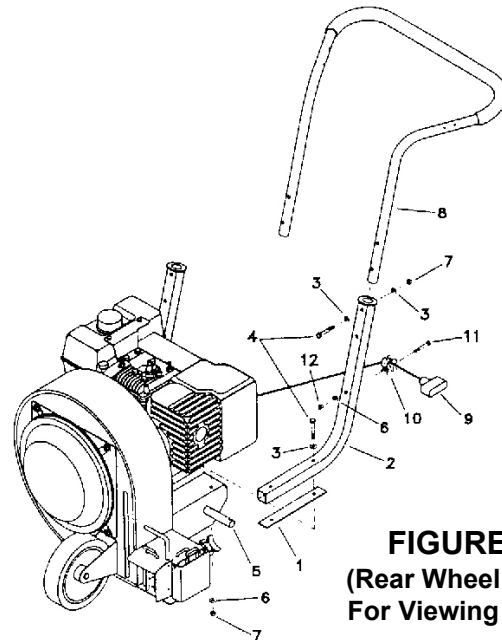

FIGURE 2
(Rear Wheel is Off
For Viewing Only)

THROTTLE CABLE ASSEMBLY

From operator position, the throttle cable can be installed on outside of handle on right side or on inside of handle on left side. To install throttle cable (1) to handle (5), place #10 washers (3) between throttle cable (1) and handle (5) as shown. Insert 10-24 screws (2) through throttle cable (1), washers (3) and handle (5) and tighten with 10-24 nyloc nuts (4). Mount snap mount (6) and cable to handle (5). Place and tighten cable tie (7) and cable around handle strut (8).

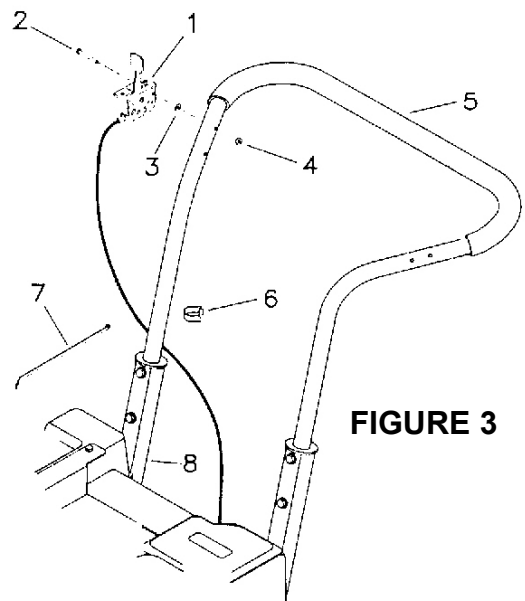
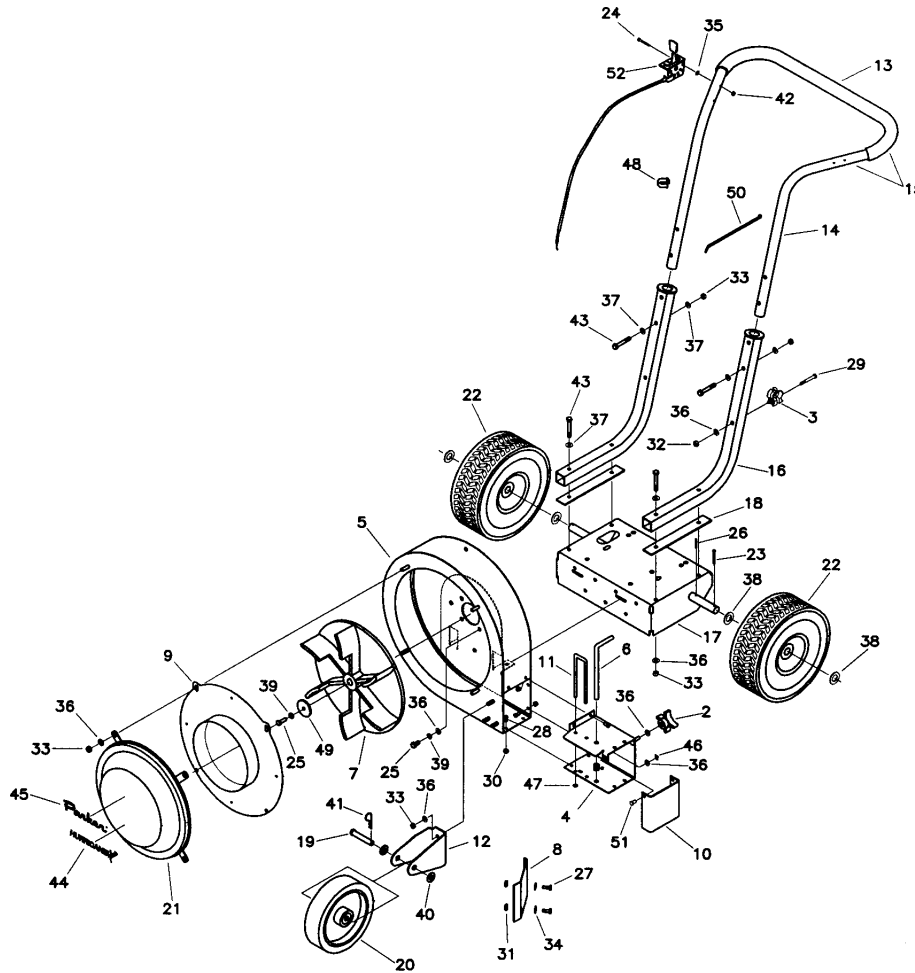

FIGURE 3

BLOWER FRAME ASSEMBLY



PARTS LIST

ITEM	PART NO.	REQ'D	DESCRIPTION	ITEM	PART NO.	REQ'D	DESCRIPTION
1	170051	1	SPRING-SWITCH	27	710231	2	SCR-MC 8-32 X .75 ZINC
2	350139	1	KNOB-5/16 THREAD	28	710355	6	SCR-MC 10-32 X .50 ZINC
3	350186	1	KIT-ROPE GUIDE	29	711220	1	BLT-HH 1/4-20 X 2.50 STL ZINC
4	360001	1	DUCT BLOWER	30	711350	6	NUT-NYLOC 10-32
5	360005	1	HOUSING BLOWER ASY	31	711372	2	NUT-NYLOC 8-32
6	360006	1	LEVER VALVE CONTROL	32	711373	1	NUT-NYLOC 1/4-20
7	360011BAL	1	CSTG-BLOWER FAN BAL	33	711374	14	NUT-NYLOC 5/16-18
8	360020	1	FLAP BLOWER DOOR	34	711502	2	WSR-FLT #8
9	360022	1	RING GRILL ADAPTOR WELD	35	711503	2	WSR-FLT #10
10	360100	1	BLOWER DOOR	36	711506	18	WSR-FLT 5/16 (NARROW) ST PL
11	360102	2	BLOWER GUARD	37	711507	12	WSR-FLT .37 X 1.12 X .06
12	360104	1	WHEEL BRACKET	38	711512	4	WSR-FLT .75 X 1.37 X .08
13	360108	1	SLEEVE-HANDLE	39	711545	5	WSR-HELICAL 5/16
14	360109PTD	1	HANDLE BLOWER PAINTED	40	711592	2	WSR-FLT .50 X .90 X .075 NYL
15	360110	1	HANDLE ASM	41	711670	1	PIN-HAIRPIN COTTER 21-06 1/2
16	360112	2	SQ TUBE WELDMENT	42	712638	2	NUT HEX 10-24 SS NYLOC
17	360120	1	FRAME WELDMENT	43	713031	8	BLT-HH 5/16-18 X 2 #5
18	360129	2	RUBBER SHIMS .	44	715185	1	DECAL-HURRICANE PLUS 5
19	360131	1	PIN 1/2 X 2 3/4 11-237	45	715322	1	DECAL-PARKER DIECUT MED
20	360133	2	WHEEL-8 X 2 W/.5 BORE BLK	46	75-80-A	4	SHAFT RETAINER
21	360136	1	FAN GUARD ASSEMBLY	47	75-89-A	2	NUT-SPEED 1/4
22	360140	2	WHEEL-PNEU 3/4 BORE	48	80-276-A	1	SNAP MOUNT
23	380-532-20	2	PIN-COTTER	49	82-138-B-1	1	WSR-SPECIAL
24	515-10-24	2	SCR-RD HD 10-24 X 1 1/2	50	828062	1	CABLE TIE LARGE
25	60-516-16	5	BLT-HH 5/16 X 1 #5	51	831889	1	PIN-CLEVIS 5/16 X 1/2
26	67-521-A	2	PIN-ROLL	52	83-25-B-33	1	CABLE-THROTTLE CONTROL ASSY

BRIGGS & STRATTON 6.5 HP

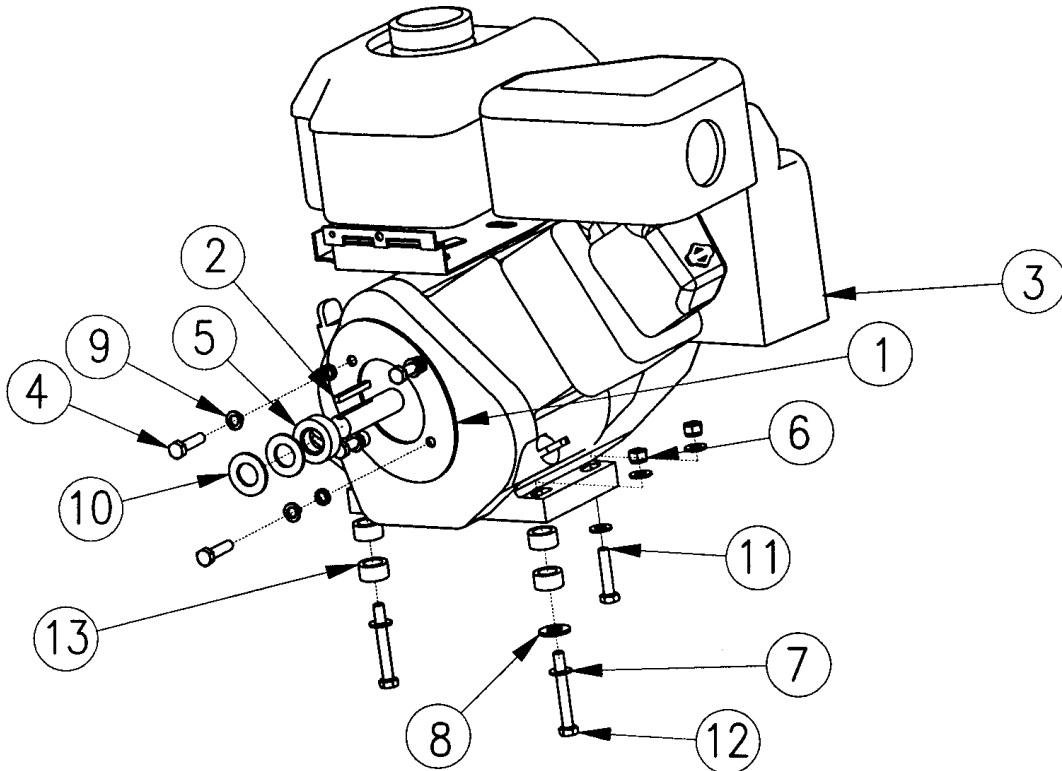

PARTS LIST

ITEM	PART NO.	REQ'D	DESCRIPTION
1	350320	1	ENGINE SPACER
2	360018	1	KEY-FAN WHEEL
3	360024	1	6.5 HP B/S INTEK
4	60-516-16	4	BLT-HH 5/16 X 1 #5
5	64-134-A	2	SPACER-.75 X 1.43 X .25
6	711374	4	NUT-NYLOC 5/16-18
7	711506	12	WSR-FLT 5/16 (NARROW) ST PL
8	711508	1	WSR-FLT .44 X 1.00 X .08
9	711545	4	WSR-HELICAL 5/16
10	712765	2	WSR-FLT .75 X 1.375 X .09 SS
11	713029	2	BLT-HH 5/16-18 X 1 1/2 #5
12	713033	2	BLT-HH 5/16-18 X 2 1/2 #5
13	833744	4	BUSHING-.50 X .75 X .40

HONDA 5.5 HP

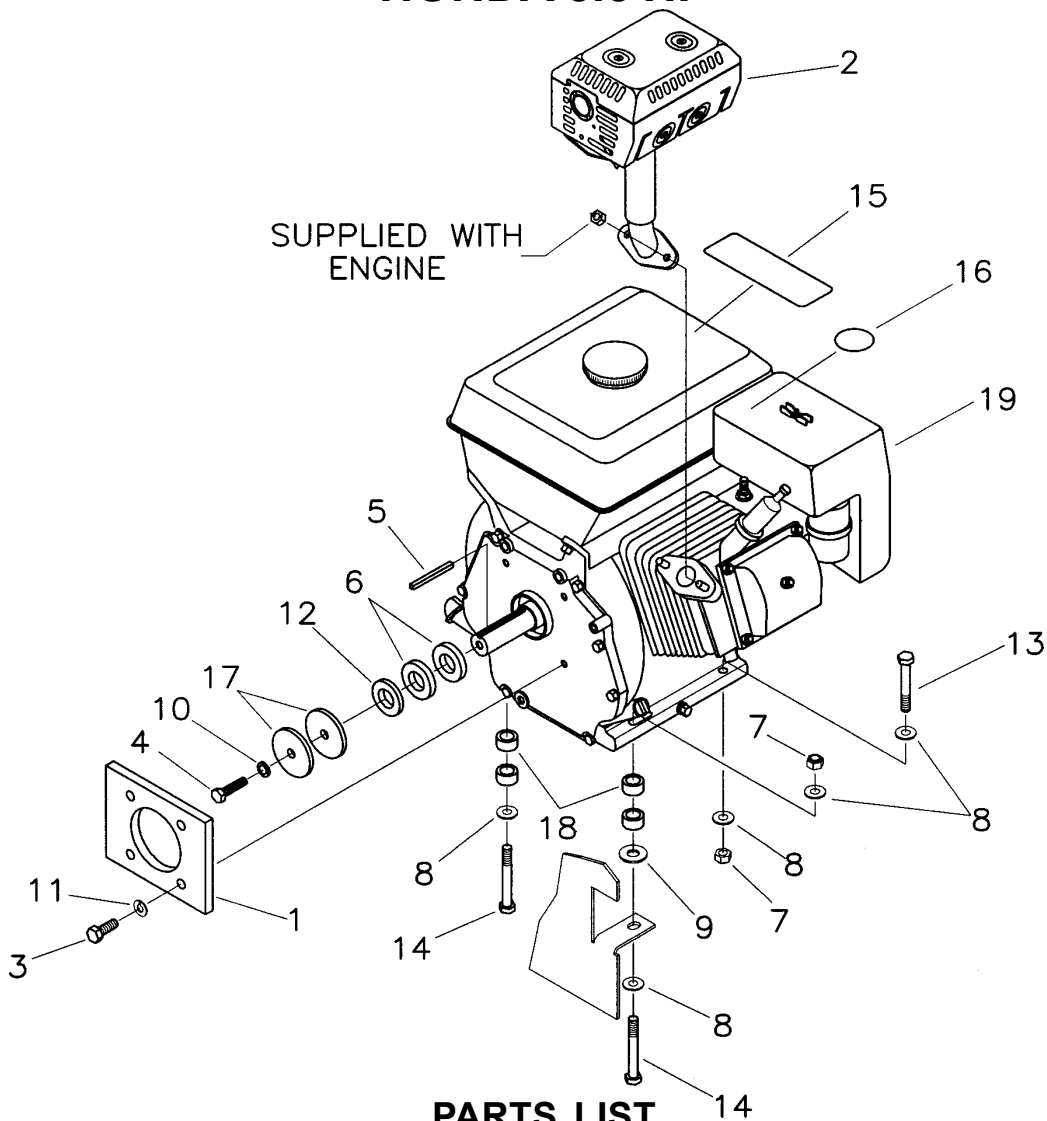

PARTS LIST

ITEM	PART NO.	REQ'D	DESCRIPTION
1	360030	1	SPACER PLATE HONDA 5HP
2	360033	1	MUFFLER ASY 5HP HONDA
3	60-516-16	4	BLT-HH 5/16 X 1 #5
4	60-516-20	1	BLT-HH 5/16-24 X 1.25 #5
5	61-65-A	1	KEY-3/16 X 1 3/4 LONG
6	64-134-A	2	SPACER-.75 X 1.43 X .25
7	711374	4	NUT-NYLOC 5/16-18
8	711506	8	WSR-FLT 5/16 (NARROW) ST PL
9	711508	1	WSR-FLT .44 X 1.00 X .08
10	711545	1	WSR-HELICAL 5/16
11	711565	4	WSR-EXT LOCK 5/16
12	712765	1	WSR-FLT .75 X 1.375 X .09 SS
13	713030	2	BLT-HH 5/16-18 X 1 3/4 #5
14	713033	2	BLT-HH 5/16-18 X 2 1/2 #5
15	715314	1	DECAL-WARNING BURN
16	715321	1	DECAL-HEARING PROTECTION
17	82-138-B-1	2	WSR-SPECIAL
18	833744	4	BUSHING-.50 X .75 X .40 ALM
19	91-10	1	ENGINE-5.5HP HONDA

LIMITED WARRANTY

The Parker Sweeper Company warrants to the original purchaser/user that this product is free from defects in workmanship and materials under normal use and service for a period of two years from date of purchase. In addition, Parker Sweeper Company will, at its option, honor labor warranty claims for the first 12 months from date of sale, provided such claims are submitted through and approved by factory authorized repair stations. Parker Sweeper Company will, at its option, repair or replace without charge, except for transportation costs, parts that fail under normal use and service when operated and maintained in accordance with the applicable operation and instruction manuals.

This warranty does not apply to normal wear, or to items whose life is dependent on their use and care, such as belts, cords, switches, hoses, rubber parts, electrical motor components or adjustments. Parts not manufactured by Parker Sweeper Company such as engines, batteries, battery chargers, hydraulic pumps, and tires are covered by and subject to the warranties and/or guarantees of their manufacturers. Please contact Parker Sweeper Company for procedures in warranty claims against these manufacturers.

Special warning to purchaser — Use of replacement filters and/or prefilters not manufactured by Parker Sweeper Company or its designated licensees, will void all warranties expressed or implied.

A potential health hazard exists without exact original equipment replacement.

All warranted items become the sole property of Parker Sweeper Company or its original manufacturer, whichever the case may be.

Parker Sweeper Company disclaims any implied warranty, including the warranty of merchantability and the warranty of fitness for a particular purpose. Parker Sweeper Company assumes no responsibility for any special, incidental or consequential damages.

This limited warranty is applicable only in the U.S.A. and Canada, and is extended only to the original user/purchaser of this product. Customers outside the U.S.A. and Canada should contact their local distributor for export warranty policies. Parker Sweeper Company is not responsible for costs or repairs performed by persons other than those specifically authorized by Parker Sweeper Company. This warranty does not apply to damage from transportation, alterations by unauthorized persons, misuse or abuse of the equipment, use of non-compatible chemicals, or damage to property, or loss of income due to malfunctions of the product.

If a difficulty develops with this machine, you should contact the dealer from whom it was purchased.

This warranty gives you specific legal rights, and you may have other rights which vary from state to state. Some states do not allow the exclusion or limitation of special, incidental or consequential damages, or limitations on how long an implied warranty lasts, so the above exclusions and limitations may not apply to you.

Minuteman[®]
Parker[®]

A Minuteman International Company

World Headquarters
Minuteman International, Inc.
111 South Rohlwing Road
Addison, Illinois 60101

PHONE: (630) 627-6900
FAX (630) 627-1130
www.minutemanintl.com

Minuteman Canada, Inc.
2210 Drew Road
Mississauga, Ontario
L5S 1B1

PHONE: (905) 673-3222
FAX (905) 673-5161

988219
Printed in U.S.A.